



exo990MGE

SWIR

The SWIR cameras based on the EXO and FXO series offer an extremely wide usable spectral range of 400-1700nm with the Sony SenSWIR sensor. Highly efficient thermal management of the housing is the basis of the outstanding dynamic range and homogeneity of the image. The integrated 4-channel strobe controller supports complex illumination and analysis scenarios.

Technical Highlights

- > Switchable active cooling (FXO only)
- > GenICam 3.0, GenTL
- > Integrated 4-channel LED strobe controller
- > I/O interface with 2xIN, 4xOUT, Opto and RS232
- > programmable timer, logic functions and sequencer
- > Two-Point NUC (Non Uniformity Correction)

ATTENTION: This product is subject to export control and requires written information on intended use and final destination!



SWIR / UV / Polarized Series exo990MGE

Resolution [MP]	1.3 MP
Resolution (h x v)	1280 x 1024 px
Frame rate (max.)	94.4 fps
Chroma	SWIR
Interface	GigE Vision (RJ-45)

Sensor

Sensor	IMX990AABJ
Manufacturer	Sony
Sensor type	Area SWIR CMOS
Shutter type	global shutter
Sensor size (h x v)	6.4 x 5.12 mm
Optical diagonal	8.2 mm
Sensor format	8.2mm (Typ 1/2)
Pixel size (h x v)	5 x 5 μm

Camera

Exposure modes	MANUAL;AUTO
Trigger modes	INTERNAL;SOFTWARE;EXTERNAL
Exposure time (min)	21 μs
Exposure time (max)	0.5 sec
Pixel format / max	mono8, mono12 / 12 bit
Gain modes	manual, auto
Dynamic range (max)	57 dB (dep. on environment)
Internal memory	256 MB SDRAM, 32 MB Flash

Feature Set

AOI	yes
LUT	yes
Offset	yes
Readout control	yes
Binning	yes
Image flip	yes
Two-Point NUC	yes
Defect pixel correction	yes
Sequencer	yes
POE	yes
Dynamic HotPixel Correction	yes

Housing

Lens mount	C-Mount
Dimensions (w x h x d)	50 x 50 x 42.5 mm

Dimensions [mm]

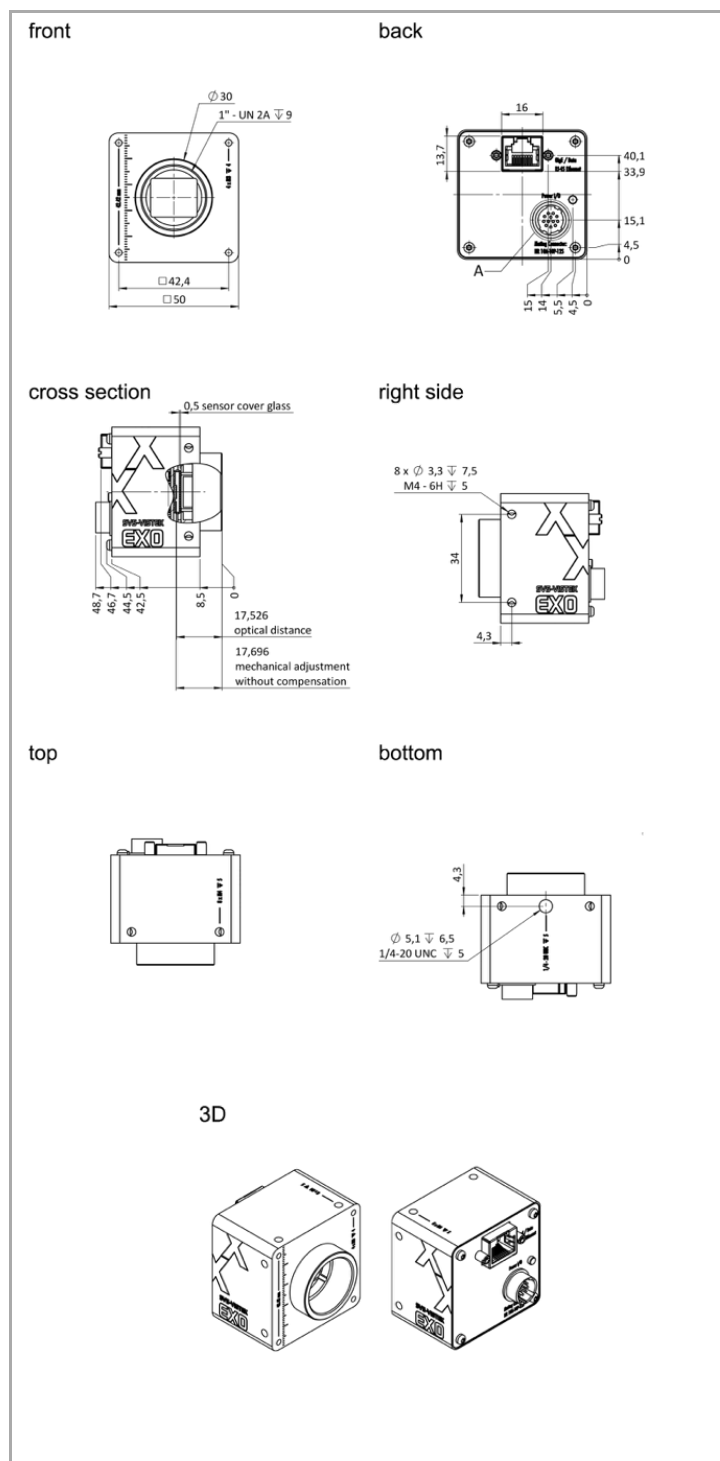

Pinout Mating Connector

	1	VIN - (GND)	7	OUT 1 (open drain)
	2	VIN + (10V to 25V DC)	8	OUT 2 (open drain)
	3	IN 4 (RXD RS232)	9	IN 3 + (opto In +)
	4	OUT 4 (TXD RS232)	10	IN 3 - (opto In -)
	5	IN 1 (0-24V)	11	OUT 3 (open drain)
	6	IN 2 (0-24V)	12	OUT 0 (open drain)

Weight	138 g
Operating temperature (housing)	-10 to 60 °C
Ambient humidity	10 to 90 % (non-condensing)
Protection class	IP40

I/O-Interfaces

Input up to 24V	2 x
Input OPTO	1 x
Output open drain	4 x
I/O RS-232	1 x
Power supply	10 to 25 V (DC)
Power consumption	4 W (dep. on operating mode)

Spectral Response *

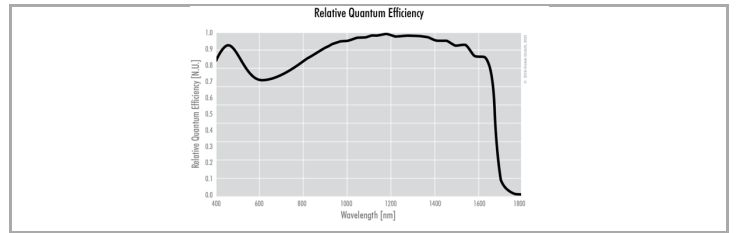

* Sensor data – excludes camera cover- or IR-cut filter characteristics