

RESONON

PIKA IR-L+ HYPERSPECTRAL CAMERA



The Pika IR-L+ is a line-scan hyperspectral camera that covers the near-infrared spectral range (925 – 1700 nm). The Pika IR-L+ is a high-precision, light-weight infrared imager, ideal for those who need the best remote sensing data. It can be used with any of Resonon's benchtop, outdoor, and airborne systems, standalone with our software development kit, and integrated into machine vision systems.

FEATURES

- Spectral Range: 925 – 1700 nm
- 640 Spatial Pixels Per Line
- 470 Spectral Channels Per Line
- 3.8 nm Spectral Resolution (FWHM)

SPECTRAL RESPONSE

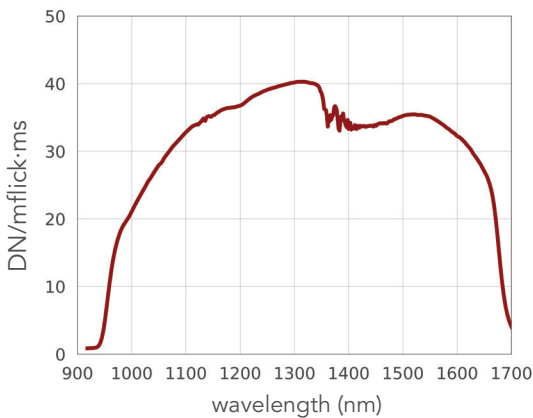

ACTUAL DATA

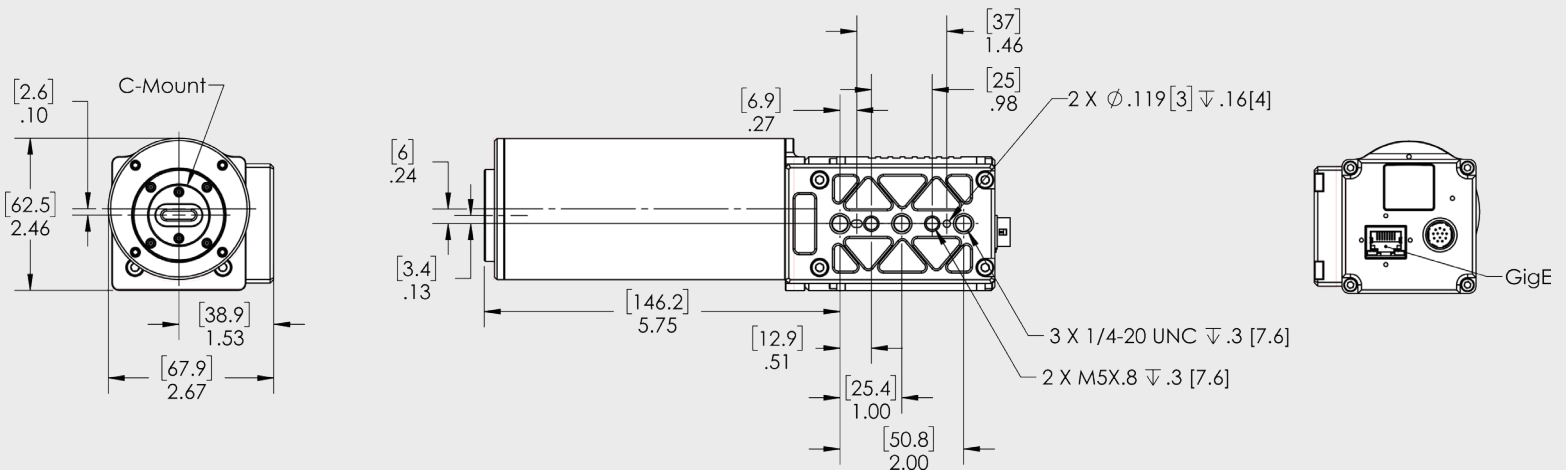
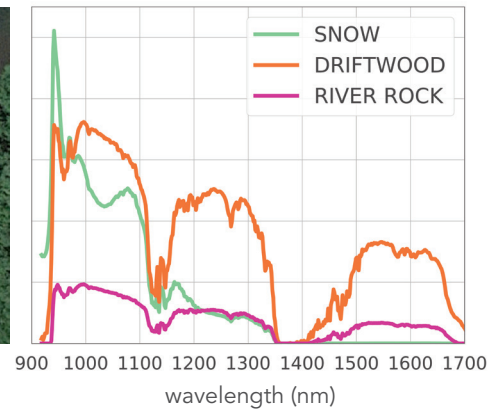
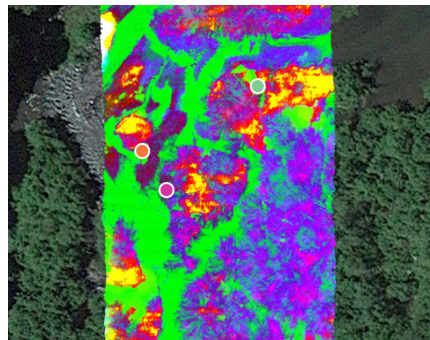

PIKA IR-L+ SPECIFICATIONS

Spectral Range	925 - 1700 nm
Spectral Channels^[1]	470
Spectral Bandwidth	1.7 nm
Spectral Resolution (FWHM)	3.8 nm
Dispersion per Pixel	1.7 nm
Spatial Pixels per Line	640
f/#	1.8
Dimensions	210 x 68 x 63 mm
Weight (without Lens)	1.01 kg
Power Requirements	10.8 V to 30.0 V
Max Frame Rate	176 fps
Interface	GigE
Bit Depth	14
Pixel Size	15 μ m
Peak SNR^[2]	1095
Binning	spectral and spatial available
Pixel Well Depth	1.2 Me-
Slit Width	15 μ m
Spectrometer Magnification	1.0
Sensor Type	InGaAs
Sensor Cooling	TEC
Operating Temperature (non-condensing)	-20 to +50 C
Recommended Temperature (non-condensing)	+5 to +40 C
Objective Lens Mount	CS-mount
Objective Lens Field-Of-View Options	5°, 7°, 11°, 22°, 77°
Software Development Kit	Windows, C++

[1] This is the number of spectral channels spanning 925 – 1700 nm. The total number of spectral channels delivered by the Pika IR-L+ is 480, with bands extending beyond both edges of the Spectral Range.

[2] This value obtained at minimum binning. SNR can be increased with spectral and spatial binning.

Sample data and hyperspectral analysis software are available for free download at downloads.resonon.com.

A C++ software development kit is available for direct control of our hyperspectral cameras.