

# Time-Resolved Multispectral Imaging of Combustion Reactions

Infrared thermal imaging is used for a wide range of applications, especially in the combustion domain. However, it is well known that most combustion gases such as carbon dioxide (CO<sub>2</sub>), water vapor (H<sub>2</sub>O) and carbon monoxide (CO) selectively absorb/emit infrared radiation at discrete energies, i.e. over a very narrow spectral range. Therefore, temperature profiles of most combustion processes derived from conventional broadband imaging are inaccurate without prior knowledge or assumptions about the spectral emissivity properties of the combustion gases. Using spectral filters allows to estimate these critical emissivity parameters in addition to providing selectivity regarding the chemical nature of the combustion gases. However, due to the turbulent nature of most flames, it is crucial that such information be obtained without sacrificing temporal resolution. For this reason, Telops has developed a time-resolved multispectral imaging system which combines a high performance broadband camera synchronized with a rotating spectral filter wheel. In order to illustrate the benefits of using this system to characterize combustion experiments, measurements were carried out using Telops MS-IR MW on very simple combustion system representative of a laminar flame: a candle. The temperature profiles calculated using the spectral information from the different channels were compared with corresponding temperature profiles obtained with conventional broadband imaging. The results illustrate the benefits of the Telops MS-IR cameras for the characterization of laminar and turbulent combustion systems at a high temporal resolution.

## Introduction

Infrared imaging has been used for characterization of gas clouds for many years in which image contrast is associated with thermal contrast between the investigated gas and its background. The overall balance between the gas absorption and self-emission, relative to its background, allow to spatially resolve the presence of an infrared-active gas within the instrument field of view. For conventional broadband infrared imaging systems, a single temperature or integrated radiance value is obtained for each pixel. This value is function of all contributions from all targets emitting infrared radiation within the detector sensitivity range. Among the most commonly encountered spectral ranges are the midwave infrared (MWIR) covering between 3 to 5 μm, the longwave infrared (LWIR) between 8 to 10 μm and the very longwave infrared (VLW) between 8 to 12 μm. The MWIR spectral range is usually considered as the most suitable spectral range to characterize combustion processes since many combustion products such as water vapor (H<sub>2</sub>O), carbon dioxide (CO<sub>2</sub>) and carbon monoxide (CO), hydrocarbons

are highly infrared-active in this spectral range. In a complete combustion, the reactant such as hydrocarbons burn with an excess of oxygen (O<sub>2</sub>) to produce CO<sub>2</sub> and H<sub>2</sub>O as shown in Equation 1.

### Equation 1

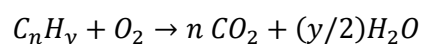

When the proper stoichiometry is not respected or when the temperature is too low, incomplete combustion will occur. Such combustions typically generate CO in addition to the presence of unburnt reactants and/or soot (C<sub>(s)</sub>) as shown in Equation 2.

### Equation 2

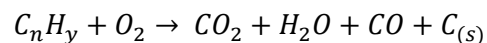

When the reactants contain elements such as sulfur or chloride, other combustion by-products such as sulfur dioxide (SO<sub>2</sub>) and hydrogen chloride (HCl) can be found. At high temperatures, NO<sub>x</sub> can also be produced due to the oxidation of nitrogen in the air.

It is well known that absorption and self-emission of infrared radiation is function of wavelength for most gases (spectral emissivity). Their absorption/emission patterns often refer to their infrared spectral signatures. Such spectral features result from molecular vibration energy transitions which are very unique to each molecule. By using conventional broadband imaging systems, it is thus obvious that limited thermal contrasts associated with combustion gases are obtained due to the fact that absorption/self-emission takes place over spectral range(s) much narrower than the infrared detector sensitivity range. Moreover, it is particularly challenging, or even impossible, to distinguish an infrared-active molecule from another without spectral information. Multispectral (MS) imaging provides spectral information by tuning the detector's spectral response using filters such as band-pass (BP), low-pass (LP) and high-pass (HP) filters. These often refer as bands or spectral channels. When carefully selected, spectral filters provide improved selectivity and enhance contrast for gas imaging. Consequently, having a great selection of spectral filters provides a lot of flexibility and selectivity as it can provide finer spectral resolution by increasing the number of spectral range configurations. In this regard, filter wheel systems are of great interest as they allow storage of a selection of spectral filters readily available for acquisition.

When dealing with turbulent combustion processes, a good temporal resolution represents an important asset. For this reason, the Telops MS-IR systems are equipped with a fast-rotating motorized filter wheel synchronized with image acquisition. This allows to automatically collect frames on each spectral channel without having to handle and or select filters manually. The Telops MS-IR infrared camera's filter wheel allow storage of up to eight (8) different filters, providing enhanced flexibility over most filter wheel systems on the market. Due to its time-resolved capabilities and its spectral information, the MS system from Telops was proven to be particularly appropriated for gas cloud imaging [1].

In order to illustrate the benefits of this system to characterize combustion experiments, measurements were carried out using Telops MS-IR MW on very simple combustion system representative of a laminar flame: a candle. Temperature profiles were estimated by modeling in-band radiance (IBR) profiles derived from information obtained with the different spectral filters. The benefit of using time-resolved multispectral imaging was also illustrated by inducing turbulences upon addition of black powder (gun powder) during the measurements. The results were compared with corresponding temperature profiles obtained with conventional broadband imaging. The results show that based on spectral emissivity measurements it is possible to obtain reliable temperature profiles at a high temporal resolution even in presence of turbulences.

## Experimental Information

### The Telops MS-IR Series

Telops MS-IR imaging systems (Figure 1) are high performance cooled multispectral infrared cameras available in different models covering the complete mid-infrared spectral range. The MS-IR MW (3 – 5  $\mu\text{m}$ ) and MS-IR VLW (7.7 – 11.8  $\mu\text{m}$ ) use 640x512 pixels InSb (Indium Antimonide) or MCT (Mercury-Cadmium-Telluride) and 320x256 pixels MCT focal plane array (FPA) detectors respectively. The MS-IR-HD is a MWIR camera which uses a high-definition 1280x1024 pixels FPA detector. The MS-IR-FAST, also covering the MWIR, uses a fast 320x256 pixels FPA detector which allows image acquisition at a high frame rate, i.e. 1900 Hz at full frame. All the MS-IR infrared cameras allow splitting of the scene radiance into eight (8) different spectral bands rather than only one broadband image hereby providing spectral information about the investigated targets. The filter wheel is a fast rotating mechanism designed to maximize the camera's frame rate and can be used either in fixed or rotating mode. The filter wheel is capable of reaching up to 6000 rpm, leading to a maximum effective frame rate of 800 Hz, i.e. up to 100 Hz per channel.

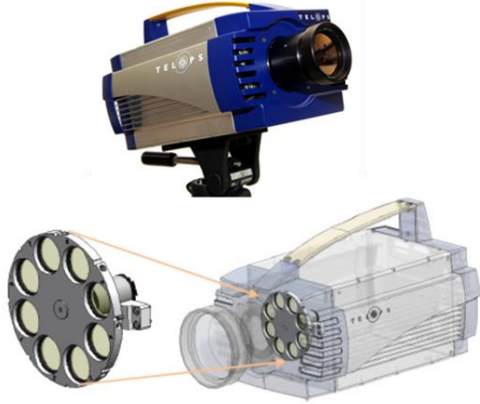

**Figure 1** The Telops MS-IR camera and the filter wheel system.

### Experimental Setup

The camera used for the experiment is a MS-IR MW in which cold filters were added in order to provide a spectral range covering between 3.7 to 4.95  $\mu\text{m}$ . The filter configuration (Figure 2) consists of one neutral density filter representative of the broadband channel (filter #1) and seven spectral filters: BP 3.7  $\mu\text{m}$  (filter #2), BP 3.9  $\mu\text{m}$  (filter #3), BP 4.0  $\mu\text{m}$  (filter #4), BP 4.19  $\mu\text{m}$  with BBP (filter #5), BP 4.45  $\mu\text{m}$  (filter #6), BP 4.63  $\mu\text{m}$  (filter #7) and BP 4.775  $\mu\text{m}$  (filter #8). For the acquisition, full FPA frame was used (640 $\times$ 512 pixels) and the integration time was set between 12 and 800  $\mu\text{s}$  depending on the acquisition channel. Total acquisition frame rate was set to 100 Hz which gives an effective frame rate of 12.5 Hz per channel. The distance between the camera and the experiment setup was 2 m.

### Image Processing

The phenomenology associated with the combustion experiment carried out in this work by remote sensing using the Telops MS-IR MW camera is described by Equation 3:

**Equation 3**

$$L_{tot} = \left( (L_{bkg}\tau_{gas} + L_{gas}(1 - \tau_{gas})) \tau_{atm} + (1 - \tau_{atm})L_{atm} \right) \tau_{filter} + (1 - \tau_{filter})L_{filter}$$

where  $L$  corresponds to the radiance and  $\tau$  corresponds to the transmittance for the background (bkg), the atmosphere (atm), the gas from the plume (gas) and the filters of the filter wheel (filter). The temperature of the filters given by the camera sensor was 23  $^{\circ}\text{C}$  while the transmittance curves for all spectral filters were provided by the manufacturer. For the gas plume, only water and carbon dioxide produced by a complete combustion have been considered since negligible contributions were measured in the other spectral channels.

In-band radiance (IBR) consists in integrating the spectral radiance over a defined spectral range (spectral filters). By combining the information from all spectral channels, IBR profiles are obtained for each pixel. Optimization of Equation 3 was carried out on the IBR profile of each pixel in order to estimate the gas plume temperature and its column density. The simulated IBR profiles were carried out using the HITRAN spectroscopic database.

## Results and Discussion

### Spectral Channels

A burning candle is among the simplest combustion systems representative of a laminar flame. Candle's waxes are mainly composed of long hydrocarbon chains (paraffin) which vaporize and combust when the molten wax reaches the flame by capillarity through the wick. Considering a complete combustion, only  $\text{CO}_2$  and  $\text{H}_2\text{O}$  are expected. A typical MWIR spectrum representative of a complete combustion, recorded using remote sensing technology, is shown in Figure 2. The different spectral filters used in the multispectral imaging experiments are also shown for illustration purposes and will be discussed later. The spectral features of  $\text{CO}_2$  (between 4.15 and 4.5  $\mu\text{m}$ ) are associated with the C=O asymmetric stretch vibration. In the case of gases, line broadening occurs as a function of temperature since higher energy rotational levels are populated. However, the atmospheric transmittance is close to 0 in the 4.2-

4.3  $\mu\text{m}$  spectral range due to the ambient  $\text{CO}_2$  between the camera and the target. Therefore, the remaining spectral features associated with hot  $\text{CO}_2$  appear as two peaks which often refer to the blue (4.18  $\mu\text{m}$ ) and red (4.37  $\mu\text{m}$ ) spikes. Some spectral features associated with water vapor can also be seen around 4.8  $\mu\text{m}$  and be observed through filters #7 and #8.

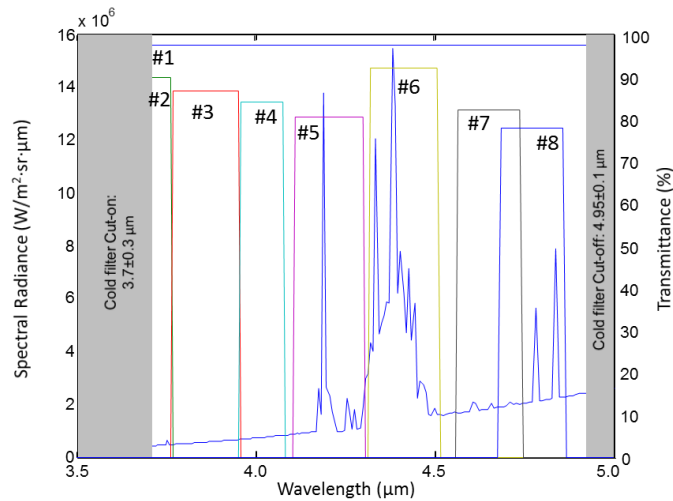

**Figure 2** Blue (4.18  $\mu\text{m}$ ) and red (4.37  $\mu\text{m}$ ) spikes from the  $\text{CO}_2$  overlaid on the transmittance of the 8 spectral filters for better evaluation.

Figure 3 illustrates the 8 successive acquisitions recorded through the different spectral channels during steady-state combustion. In order to compare the response of each filter one with another on a mutual basis, each frame was normalized using the corresponding IBR of a blackbody source at 573 K (300 °C). Filter #1 is a neutral density filter which is representative of a typical broadband camera. The broadband signal contrast is however less important compared to filter #5 and #6. This is due to the fact that the contribution of  $\text{CO}_2$  relative to the whole detector spectral range covered is very slight. As expected, the highest/most pronounced thermal contrasts for  $\text{CO}_2$  are obtained through filters #5 and #6 since the  $\text{CO}_2$  contribution relative to these filters is relatively high (as opposed to filter #1). The thermal contrast observed in filters #7 and #8 are ascribed to water vapor. Very small contrasts associated with the combustion gases can be seen through spectral filters #2-4. This is somewhat

expected as this spectral range (3.7–4.0  $\mu\text{m}$ ) is often used as "through flame" filters since  $\text{CO}_2$  and  $\text{H}_2\text{O}$  do not emit in this spectral range [2]. One of the main advantages of using such spectral filters consists in getting information about the background radiance. Such information is valuable to estimate temperature profiles as shown in Equation 3.

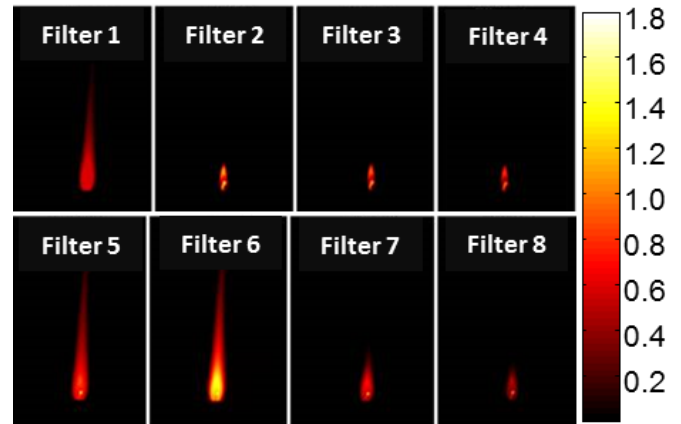

**Figure 3** Relative individual spectral channel responses during candle's combustion.

### Temperature Profiles

One common method used to calculate temperature profile is the 2 color pyrometry method, which only uses signals from filters tuned on the  $\text{CO}_2$  red and blue spikes. In this work, however, we use eight (8) different channels to estimate the temperature. A typical IBR profile associated with the combustion gases is shown in Figure 4. Indeed, most of the signal comes from channels #5-8 as discussed above. This IBR profile gives to the user access to an infrared spectrum at lower resolution, in this case, the effective spectral resolution is on the order of  $100 \text{ cm}^{-1}$ .

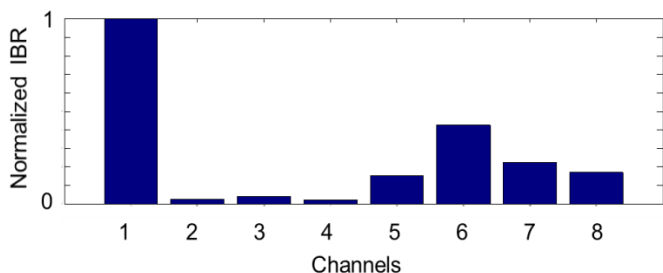

**Figure 4** Normalized IBR profile for a pixel located in the flame during the burst.

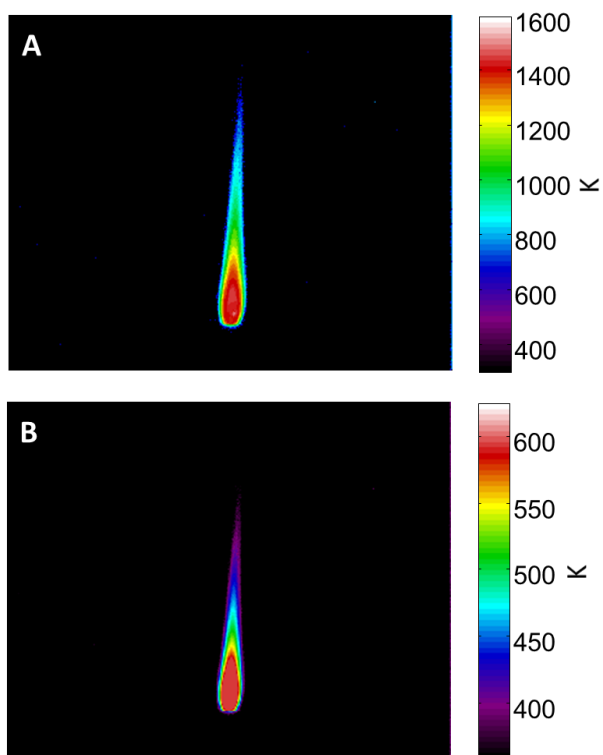

**Figure 5** A) Estimated temperature profile of carbon dioxide in the flame obtained by the optimization and B) Temperature profile of the candle's plume obtained by broadband imaging (filter #1).

Figure 5A illustrates the temperature profile obtained by estimating in-band radiance profiles for each pixels according to Equation 3. The hottest temperature is in the order of 1440 K at the bottom of the flame while it is about 690 K at the top. Results are in good agreement with prior work where temperatures in the order of 1000-1400 °C where measured [3-4]. By looking at the temperature given by the broadband image (filter #1) shown in Figure 5B, it can be seen that the bottom of the flame is about 600 K while the top of the flame is

about 400 K. This clearly shows that a broadband camera, which lacks spectral information, cannot be used in order to estimate the temperature of combustion gases. Moreover, even when using filter #6, which is tuned on the CO<sub>2</sub> red spike, the hottest temperature that is read is about 900 K. Such a value is still far from what would be expected in such situation and illustrates the emissivity assumptions required to obtain reliable temperature profiles from MWIR broadband imaging. The main difference between the estimate temperature profile and the one obtained via conventional broadband imaging is, of course, the temperature value, but also the contrast associated with combustion gases. For example, the contrast seen in Figure 5A is greater than the one in Figure 5B and this thus allows to have a better idea about the spatial distribution of the CO<sub>2</sub> and H<sub>2</sub>O during the combustion process.

### Time-Resolved Multispectral Imaging

The laminar flame has been disturbed by the addition of a small amount of black powder (gun powder) in order to induce turbulence in the system. Such chemicals are known to burn easily and thus generate a greater amount of CO<sub>2</sub> and H<sub>2</sub>O for a brief moment. Since the camera is equipped with a fast motorized filter wheel, it allows to capture such brief events at the same time as it collects spectral information. Figure 6 shows a few consecutive temperature profiles recorded during the burst induced upon addition of black powder. In the present conditions, the burst lasted less than one second. Nevertheless, due to its fast rotation, the filter wheel allowed to collect sufficient spectral information to cover the entire event. Such a temporal resolution thus allowed to see localized vortexes associated with the swift deflagration. Figure 6 also illustrates that combustion gases takes more room, both in width and height, compared with steady state combustion. The bright object on the lower left portion of the image corresponds to the spatula used to introduce the black powder over the flame.

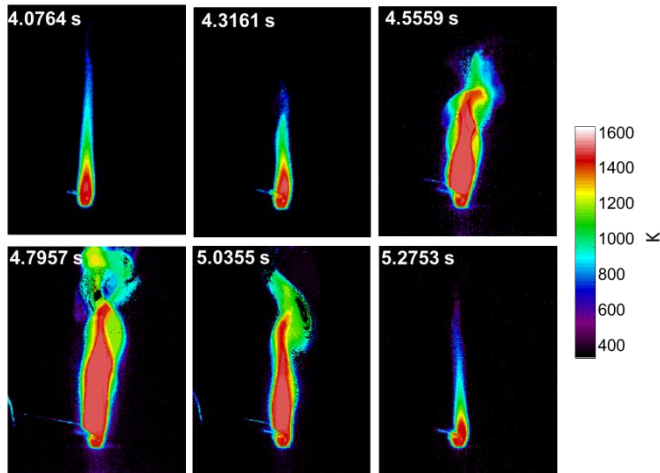

**Figure 6** Temperature profile of the plume during the explosion generated by the burning of black powder.

By looking at individual spectral channel, mainly the "through flame" filters, it is possible to detect the presence of some particles upon addition of the black powder. These particles did not show any particular spectral features thus behaving as grey bodies. A few consecutive frames recorded through filter #3 during the burst are shown in Figure 7. These particles were attributed as soot particles which are known to behave like blackbodies.

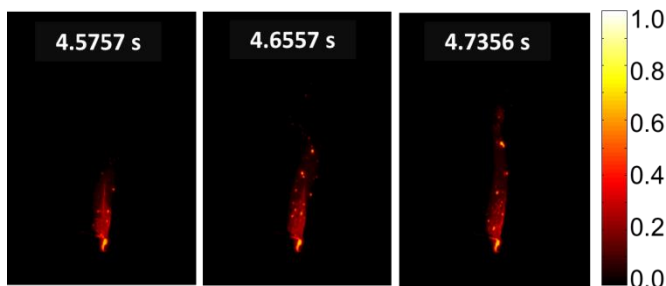

**Figure 7** Carbon soot seen using the "through flame" filter (filter #3) for 3 consecutive wheel turns.

## Conclusion

Combustion reactions are known for producing mostly carbon dioxide and water. The emissivity of these combustion gases needs to be taken into account in order to get reliable temperature measurements. Using spectral information obtained by multispectral imaging,

it is possible to get quantitative information such as temperature profiles. The comparison between multispectral and broadband imaging conducted in this work highlighted the importance of the spectral information to obtain reliable temperatures profiles. These profiles obtained from the multispectral imaging information were found systematically higher than the one obtained by broadband imaging. This is due to the selective absorption/emission nature of the combustion gases. Telops MS-IR cameras provide spectral resolution at high temporal resolution which is particularly convenient for turbulent flame systems. The Telops MS-IR series represent a good compromise between broadband and the hyperspectral imaging in terms of size, of price, of sensitivity and temporal resolution, the latter being critical for characterization of combustion reactions.

## References

- [1] Gagnon, M.A. et al., "Time-resolved thermal infrared multispectral imaging of gases and minerals," Proc. of SPIE 9249, (2010).
- [2] Vollmer, M. and Möllmann, K.-P., [Infrared Thermal Imaging], WILEY-VCH Verlag GmbH & Co. KGaG, Weinheim, 128 (2010).
- [3] National Candle Association, "Candle Science", <<http://candles.org/candle-science/>> (23 February 2015).
- [4] Gaydon, A.G. and Wolfhard, H.G., [Flames: Their structure, radiation and temperature], Chapman and Hall, London, 154-155 (1979).

## Telops Inc.

100-2600 St-Jean Baptiste ave.  
 Québec (QC), Canada  
 G2E 6J5

Tel.: +1-418-864-7808  
 Fax.: +1-418-864-7843  
[sales@telops.com](mailto:sales@telops.com)  
[www.telops.com](http://www.telops.com)