

# exo814CU3

EXO USB3 Vision



The SVCam EXO is one of the most flexible and scalable cameras for the industrial market segment. The USB3 Vision interface is easy to integrate in your system, with a data rate up to effective 360 MB/sec. The time to market for applications is shortened, saving cost even further. Power the camera via the interface and reduce cable complexity. EXO provides Plug-and-play capability for the whole range of 2.3 to 12 MP resolutions.

## Technical Highlights

- > Up to 360 MB/s effective transfer rate
- > Leverages existing infrastructure for cables and connectors
- > Powers camera with up to 4.5 W
- > GenICam compliant
- > Cost effective / Easy implementation and interfacing

# EXO Series

# exo814CU3

Resolution	3360 x 2712 px
Frame rate (max.)	18 fps (1X-1Y) 20 fps ()
Chroma	color
Interface	USB3 Vision
<b>Sensor</b>	
Sensor	ICX814AQG
Manufacturer	Sony
Sensor type	Area CCD
Shutter type	global shutter
Sensor architecture	interline transfer
Readout type	progressive scan
Sensor size (h x v)	12.4 x 10.01 mm
Optical diagonal	15.93 mm
Sensor format	1 "
Pixel size (h x v)	3.69 x 3.69 $\mu$ m
<b>Camera</b>	
Exposure modes	MANUAL;AUTO;EXTERNAL
Trigger modes	INTERNAL;SOFTWARE;EXTERNAL
Exposure time (min)	42 $\mu$ s
Exposure time (max)	1 sec (external $\infty$ )
Pixel format / max	bayer8, bayer12packed / 12 bit
Gain modes / max	manual, auto / 18 dB
S/N ratio (max)	40.7 dB (dep. on environment)
Dynamic range (max)	60.8 dB (dep. on environment)
Internal memory	256 MB SDRAM, 32 MB Flash
<b>Feature Set</b>	
Manual white balance	yes
Automatic white balance	yes
AOI	yes
LUT	yes
Offset	yes
Binning	yes
Image flip	yes
Sequencer	yes
<b>Housing</b>	
Lens mount	C-Mount
Dimensions (w x h x d)	50 x 50 x 41.2 mm
Weight	138 g
Operating temperature (housing)	-10 to 60 $^{\circ}$ C
Ambient humidity	10 to 90 % (non-condensing)
Protection class	IP40
<b>I/O-Interfaces</b>	
Input up to 24V	2 x
Input OPTO	1 x
Output open drain	4 x
I/O RS-232	1 x
Power supply	10 to 25 V (DC)
Power consumption	6 W (dep. on operating mode)

# Dimensions [mm]

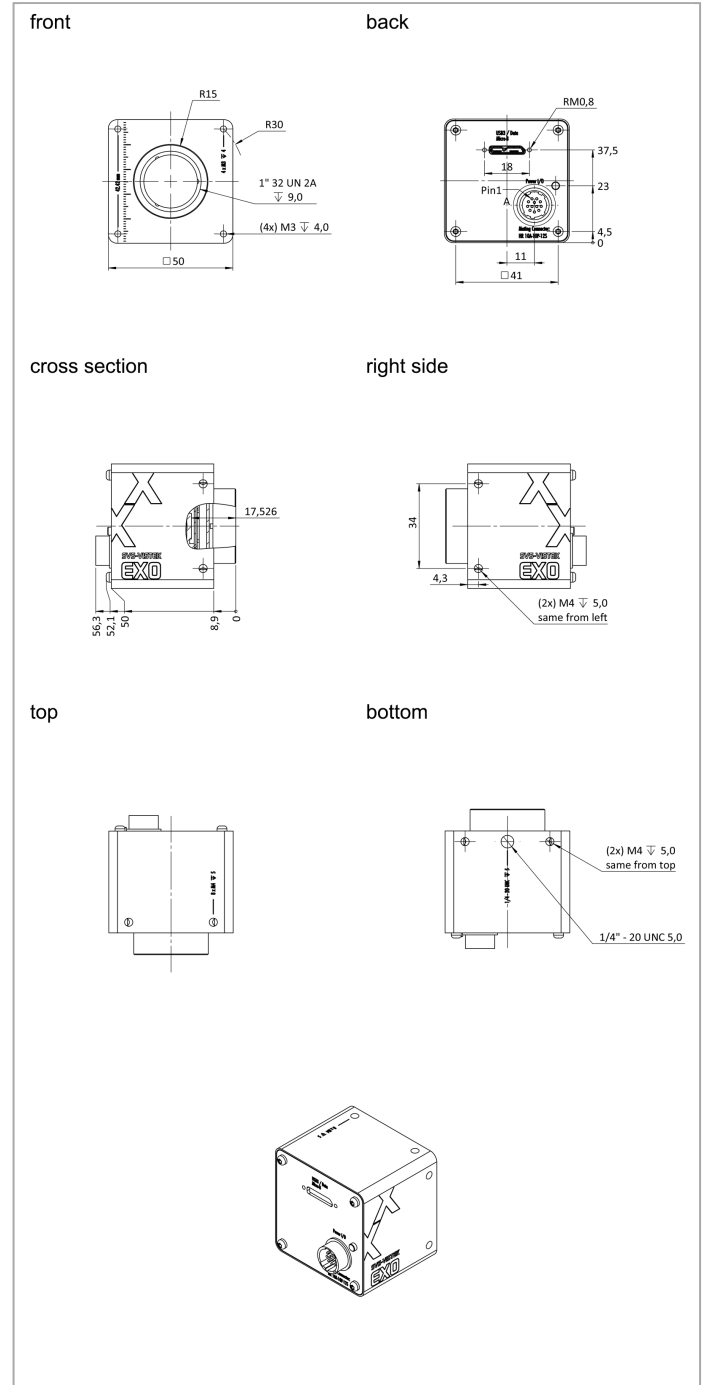

# Pinout Mating Connector

	1	VIN - (GND)	7	OUT 1 (open drain)
	2	VIN + (10V to 25V DC)	8	OUT 2 (open drain)
	3	IN 4 (RXD RS232)	9	IN 3 + (opto In+)
	4	OUT 4 (TXD RS232)	10	IN 3 - (opto In-)
	5	IN 1 (0-24V)	11	OUT 3 (open drain)
	6	IN 2 (0-24V)	12	OUT 0 (open drain)

# Spectral Response \*

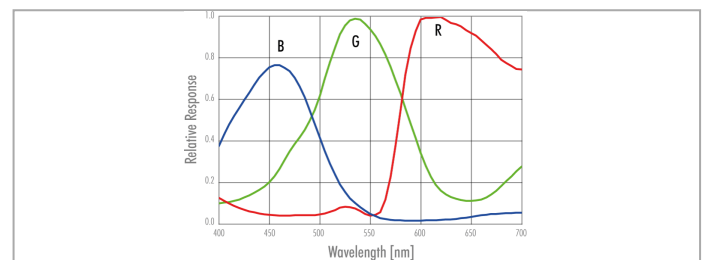

\* Sensor data – excludes camera cover- or IR-cut filter characteristics

